

## Setup Instructions

1. Place the speakers on the stands at a height of approx 5' to 6' high and 6' minimum apart. Make sure stands are on a level surface and legs are spread to at least a 3' diameter circle.

2. Find a suitable spot to place the mixer/amp. CHECK THAT ALL VOLUME LEVELS ARE SET AT THE MINIMUM LEVEL AND POWER SWITCHES ARE OFF, then plug in the mixer power cord - **DO NOT TURN ON YET!**

3. Plug the supplied speaker cables (**RED STRIPE**) into the Speaker Out on the mixer, and the Input on the back of the speakers.

**Warning:** Never plug anything other than a speaker into the output of a power amp. A "speaker out" connection carries a very strong signal that can and probably will cause damage to the other components.

4. Before plugging anything into the inputs in the mixer/amp, check to see that the controls for EACH CHANNEL are set to the default settings as follows.

- EQ (Bass, Treble, Low, Mid, High, etc.) are set to their neutral "0" position with the knob in the "12 O'clock" position
- Gain/Level control is set to "0" (turn fully counter-clockwise)
- Reverb/EFX control is set to "0" (turn fully counter-clockwise)
- In the Master Section, set the Master/Main level to "0" (turn fully counter-clockwise)

5. Plug the supplied microphone cable (**BLUE STRIPE**) into an input channel of the mixer/amp and connect the other end to the microphone. Repeat this for as many microphones as needed.

6. If using an iPod/MP3 Player for your backing tracks or break music, plug it in as shown using the supplied iPod cable.

7. Check that all master and channel volume levels are turned down, power switches are OFF and all cables are connected correctly BEFORE SWITCHING ON THE MAINS POWER on the mixer/amp.

8. At the end of the gig turn the Master/Main levels on the mixer/amp all the way down (turn fully counter-clockwise), then turn off the mixer power BEFORE disconnecting plugs and cables.

### DO

- Keep your cables neat and tidy to avoid tripping and pulling the cables out of the sockets.
- Make sure that your mics are all set up behind your speakers. This will help prevent feedback problems.
- At the end of the show coil the cables gently and neatly into a 1' diameter coil.
- Have Fun!

### DONT

- Plug anything but Speaker Cables into the Speaker Outputs!
- Cover the vents on any equipment
- Have glasses full of liquid on stage or placed on speakers/amps or equipment. Drink from a screwtop or resealable bottle (less likely to spill & ruin your electrical equipment & cause electrocution or severe equipment damage!).
- Block emergency exits with equipment
- Have loose trailing cables that people can trip over!

The latter are very important, local Health & Safety departments can stop your performance and fine you if these exits are not accessible and you certainly wouldn't want an audience member to be injured by tripping over your cables or falling equipment.



# System 2

802.863.8652

WWW.ADVANCEMUSICVT.COM

## ADVANCE MUSIC

## Speakers

Connect one end of each speaker cable (red stripe) to the SPEAKER OUT jacks on the rear of the mixer. Connect the other end of each speaker cable to the FULL RANGE INPUTS on the back of each speaker.

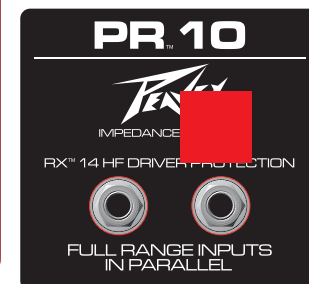

## Microphones

Using the supplied mic cable (blue stripe), plug one end into the microphone, and the other end into an input channel on the mixer (blue tape). Use the Level control to set the volume.



## iPod/MP3 Player

Using the supplied iPod cable, plug the 1/8" end into the headphone jack of the iPod or MP3 player. Plug the end with the two RCA plugs into the CD/TAPE input on the mixer. Use the CD/TAPE Level control to set the volume.

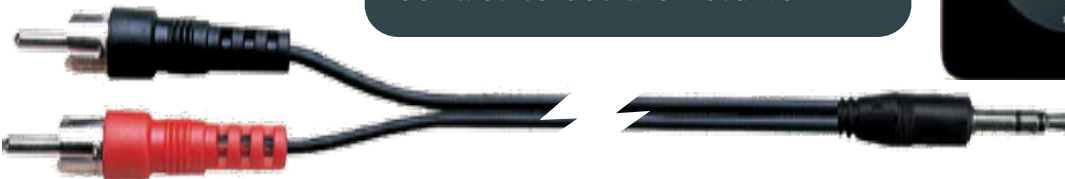

# PA SYSTEM CONTROLS & OPERATION GUIDE

## Operating the PA System

Gradually turn the Master/Main knob up about half way (twelve o'clock), this is a good starting point. Just make sure you don't turn it all the way up, or all the way down. Somewhere between one quarter and three quarters is fine.

While repeating the word "check" into a microphone, gradually turn up the Gain/Level knob for that input channel until you can clearly hear your voice coming out of the speakers. If you don't hear your voice, recheck your connections and knob settings. Repeat this process for each channel. For the iPod/MP3 input press Play on your iPod/MP3 Player and slowly turn up the level for the channel until the desired level is heard.

To create your "mix", adjust the relationship of the Gain/Level controls for each channel until you find the desired balance of vocals and/or instruments. Once you have created your "mix", you can adjust the overall volume if needed using the Master/Main knob.

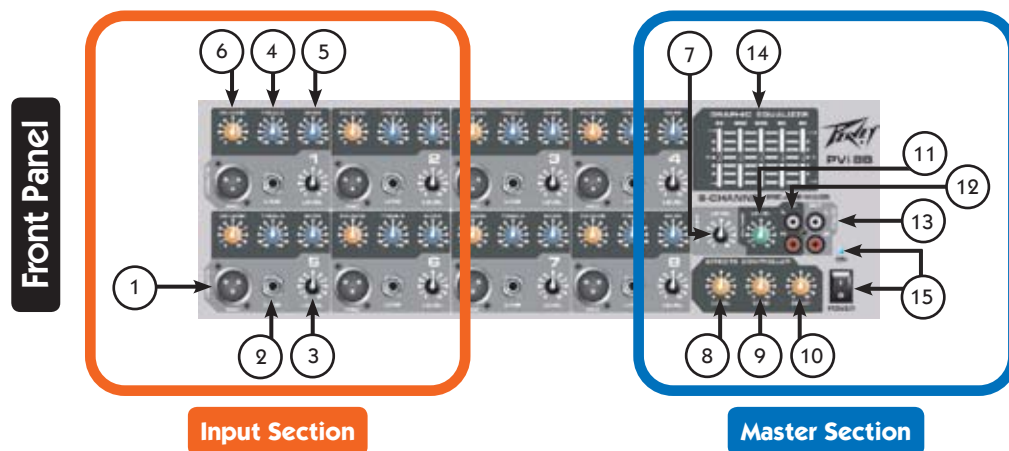

### (1) 3-PIN LOW-IMPEDANCE MICROPHONE INPUT

This input is for typical balanced, low-impedance microphones or direct boxes. It will automatically provide phantom power (15V) as needed for condenser mics or active direct boxes.

### (2) 1/4" LINE/HIGH-IMPEDANCE INPUT

This input may be used as either a high-impedance microphone input or for line-level devices such as a cassette player, CD player, video projector, laptop, electric guitar, bass or keyboard.

### (3) LEVEL CONTROL

The level control for each channel sends the signal to the master mix bus. Typical operation is between 4 and 8 (dependent upon the input devices) but should be lower than the master level. Please remember that this acts like a preamp, so if you are using a device that has a volume output control (i.e.: a tape or CD player) you will need to do some level matching by adjusting the level controls on each unit.

### (4) TREBLE TONE CONTROL

This is used to adjust the overall treble of the individual input. Since it is a cut or boost control (+/-15 dB), it will add or diminish presence frequencies in the sound beginning at 2 kHz.

### (5) BASS TONE CONTROL

This is used to adjust the overall bass of the individual input. Since it is a cut or boost control (+/-15 dB), it will add or diminish bass frequencies in the sound beginning at 300 Hz.

### (6) REVERB CONTROL

This is used as a send control to the effects bus. It controls the amount of reverberation added to the input signals.

### (7) MASTER LEVEL

This controls the overall volume level of the entire system. Typical operation is between 4 and 8.

### (8) EFFECTS VOLUME

This controls the level of the echo and delay that is added back to the master mix.

### (9) EFFECTS ECHO

This controls the character of the Reverb that is added back to the master mix. This is analogous with changing the rate at which the echo decays.

### (10) EFFECTS DELAY

This controls the delay of the Reverb that is added back to the master mix. Increase this control to simulate the effect of larger rooms.

### (11) TAPE/CD VOLUME

This controls the level of the playback inputs (RCA jacks).

### (12) TAPE IN (L/R)

These RCA jacks are for connecting an iPod or other MP3 player using the included 1/8" to RCA cable. You may also connect line sources such as a cassette deck, CD player.

### (13) TAPE OUT (L/R)

These RCA output jacks are primarily intended for connecting a tape deck, MP3 player, or other device for the purpose of recording from the mixer. Both channels are summed into mono for compatibility. The signals are taken pre-master section, meaning that they are without reverb or the master tone section, and do not include the Tape-In signal.

### (14) MASTER EQ

These are used to adjust the overall EQ of the master mix. Since these cover five frequency bands (+/-15 dB), they will add or diminish the level of the sound at the indicated frequencies, spread across approximately one octave of frequency range. Most situations should require using no more than three controls simultaneously. Do not boost or cut all five at the same time. Excessive boosting will increase the probability of feedback.

### (15) POWER

This switches the unit on or off. When the unit is powered ON, the front-panel blue LED will illuminate.

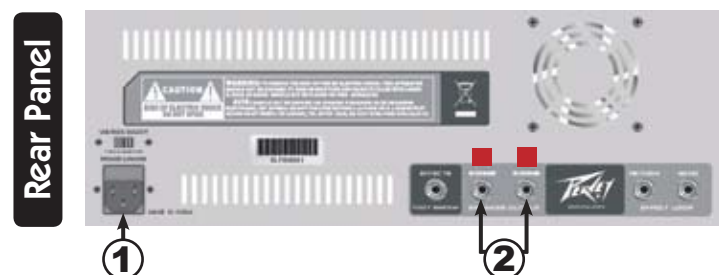

### (1) POWER CONNECTOR

This is a standard IEC AC power cable connector for use with standard voltages from AC wall outlets. Its safety ground pin is connected to the chassis and should never be removed (or defeated in the line cord) for any reason.



### (2) SPEAKER OUTPUTS

These are two-conductor 1/4" speaker outputs. Be sure to use only the speaker cables (with the red tape at each end) and not instrument cables to connect to the speakers. Each one is rated at 8 ohms minimum impedance. Total minimum load for the amplifier is 4 ohms. You may connect either one 4-ohm, one 8-ohm or two 8-ohm speakers.